



# SMOKE EXTRACTION VENTILATION FOR PARKING PREMISES

# SMOKE EXTRACTION PRODUCT CATALOGS



**MEDIUM PRESSURE AXIAL FANS AND AXIAL SMOKE EXTRACTION FANS**



**CENTRIFUGAL SMOKE EXTRACTION FANS**



**SMOKE EXTRACTION VENTILATION FOR PARKING PREMISES**



**FIRE SAFETY DAMPERS**



**60 Hz**



**MEDIUM PRESSURE AXIAL FANS AND AXIAL SMOKE EXTRACTION FANS**



**60 Hz**



**SMOKE EXTRACTION VENTILATION FOR PARKING PREMISES**



## CONTENTS

Smoke extraction systems	2
AXIS-JET. Jet axial fans	4
CENTRO-JET. Induction centrifugal fans	10
Ventilation system for underroof parking	12
Smoke extraction system for underroof parking	14
Operation of fans with frequency converters	16
Frequency converters	17

# SMOKE EXTRACTION SYSTEMS



SMOKE EXTRACTION SYSTEMS

- Smoke control is a complex process involving smoke extraction and fresh air supply by the supply and extract ventilation system of buildings in order to ensure safe evacuation of people in case of a fire in any of the spaces.
- Ventilation systems for underroof parking are designed to ensure the most important functions. Such systems are designed to protect people escaping fire through the evacuation routes against hazardous fire factors by extracting harmful combustion products and preventing their spreading in the air.
- According to conclusive evidence the majority of mortalities in a fire are caused by poisoning from carbon monoxide and other combustion products. Carbon monoxide is one of the most toxic smoke components. It is carbon monoxide poisoning that accounts for 80 % of the fire accident causes. Fires in closed spaces where oxygen supply is limited are especially prone to intensive carbon monoxide generation.

- Smoke is able to cause loss of consciousness and cardiac standstill before a person may leave a house on fire. Jet ventilation system is the most suitable and safe ventilation solution for modern underground parkings. Arrangement of such ventilation requires no ductwork layout, thus the involved mounting expenses are reduced by 45 %. The energy losses caused by aerodynamic resistance in the air ducts are also reduced. The jet ventilation system design requires no complicated annual cleaning of the ductworks, thus reducing the maintenance costs by 35-40 %.
- Axial fans are used for general ventilation purposes of underground and semiopened parkings, covered shelters, ventilation of tunnels, air recirculation in atriums and air supply to panoramic glass constructions. Such ventilation system does not require installation of ductworks and the air stream flows directly from air supply vent to air exhaust vent.

## Impurity content in the air [mg/m<sup>3</sup>] and health effect

Influence	CO	SO <sub>2</sub>	NOx
No marked effect in case of exposure for several hours	115	6	15
Symptoms of light poisoning or mucous membrane irritation in 2-3 hours	115...575	130	20
Poisoning in 30 minutes	2300...3500	210...400	100
Life hazard even if short-term exposure	5700	1600	150

## Composition of automotive exhaust gases

Content, volume in %	Petrol type	Diesel type
N <sub>2</sub>	74-77	76-78
O <sub>2</sub>	0.3-0.8	2.0-18.0
H <sub>2</sub> O (vapours)	3.0-5.5	0.5-4.0
CO <sub>2</sub>	0.0-16.0	1.0-10.0
CO*	0.1-5.0	0.01-0.5
Nitrogen oxide*	0.0-0.8	0.0002-0.5000
Hydrocarbons*	0.2-3.0	0.09-0.500
Aldehydes*	0.0-0.2	0.001-0.009
Soot** [g/m <sup>3</sup> ]	0.0-0.04	0.01-1.10
Benzpyrene <sub>3,4</sub> ** [g/m <sup>3</sup> ]	10-20 x 10 <sup>-6</sup>	10 x 10 <sup>-6</sup>

\* Toxic components  
\*\* Carcinogens

**Axis-Jet-CI axial jet fan design**

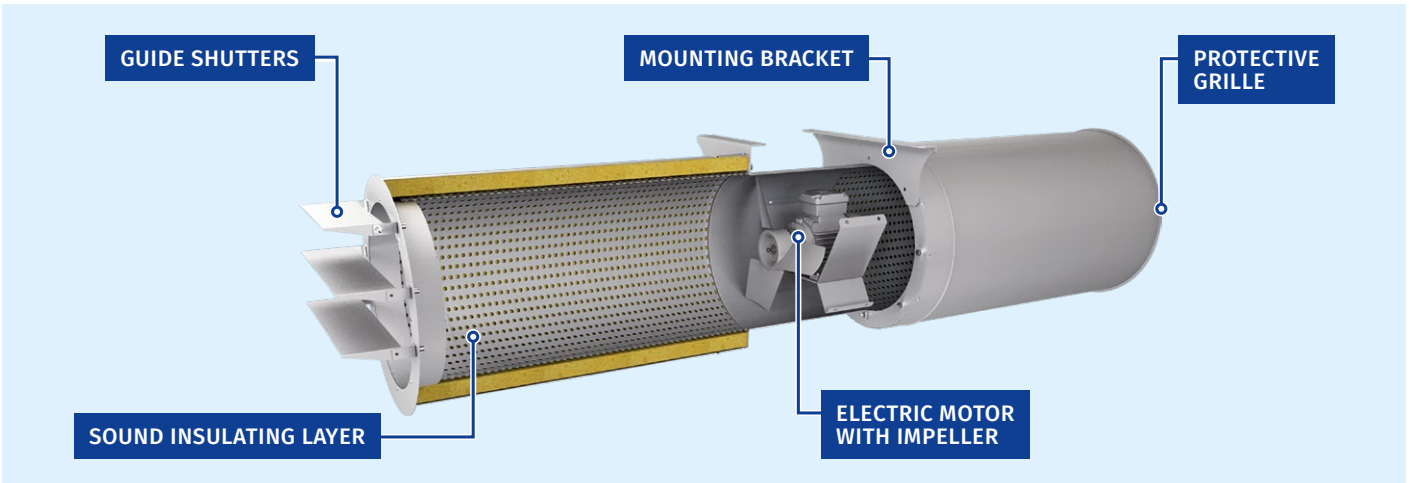

**Axis-Jet-VI axial jet fan design**

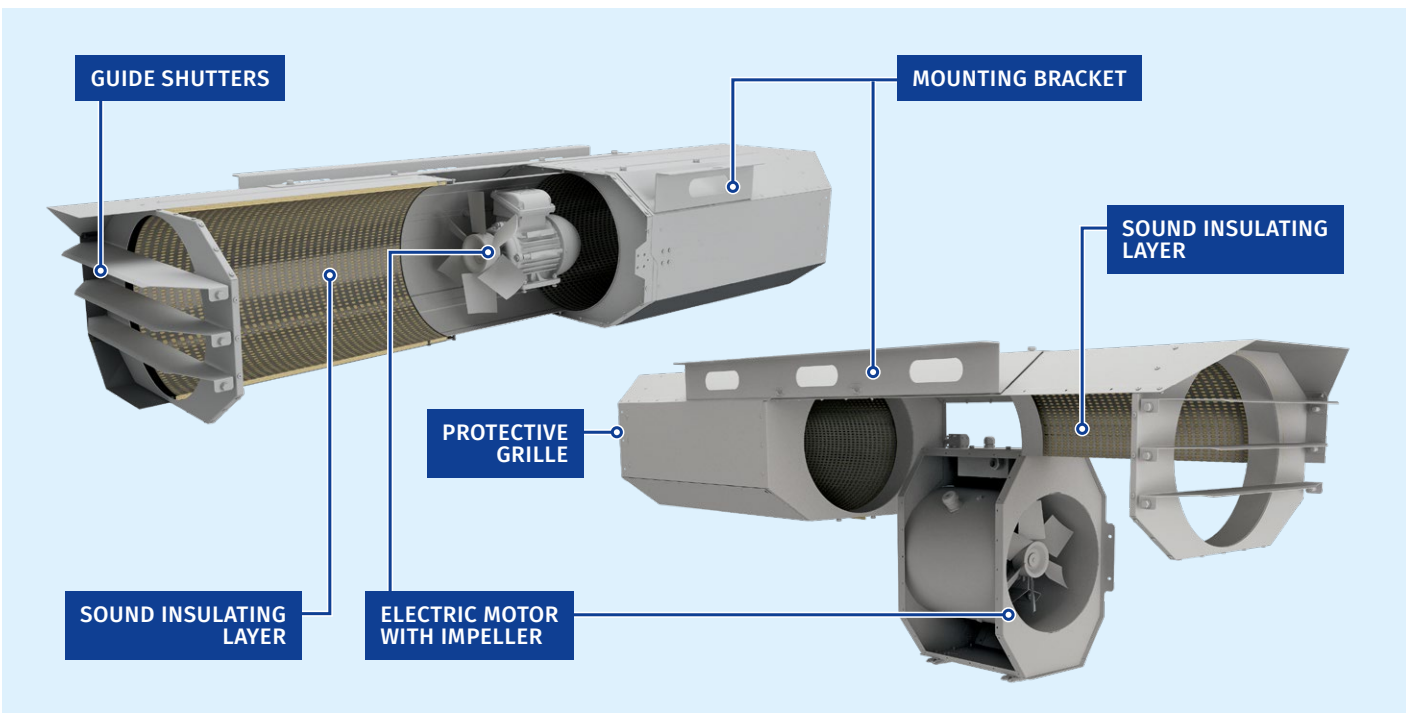

**Centro-Jet induction centrifugal fan design**

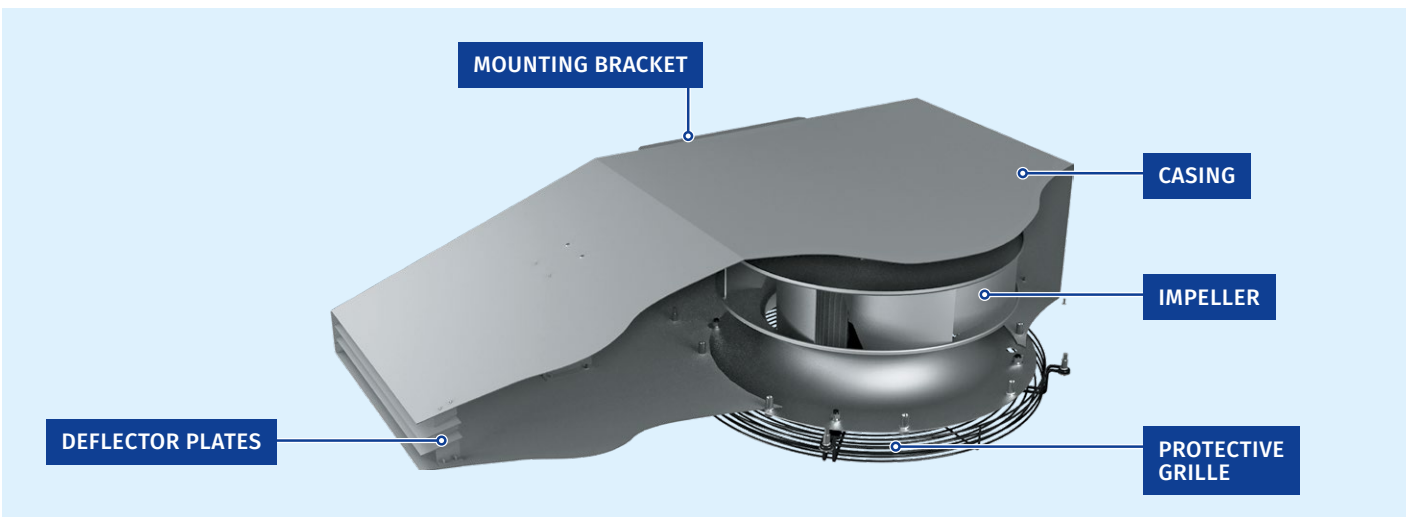

# AXIS-JET

## Jet axial fans

### Use

- The **Axis-Jet** axial fans are designed for general purpose ventilation of underground and semiopened parking, ventilation of tunnels, smoke extraction in case of fire as a part of smoke extract system. The fans generate a high-speed and high-pressure directed air jet.
- Temperatures of the transported medium: in continuous operation up to +55 °C; in smoke extraction mode: 300 °C/2 hrs and 400 °C/2 hrs
- Functionality. Power. Efficiency.

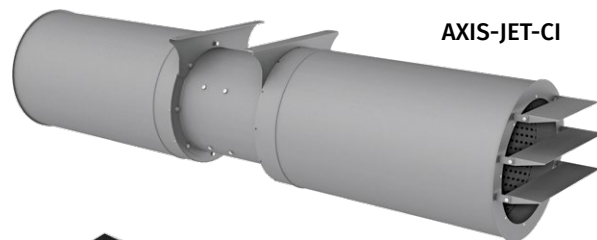

AXIS-JET-CI

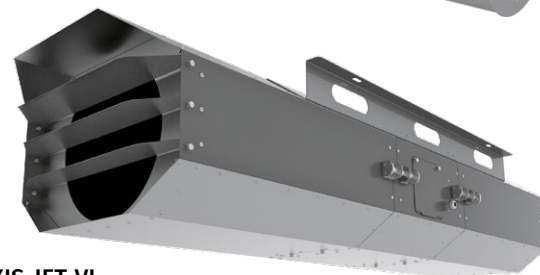

AXIS-JET-VI

### Design

- The casing of the **Axis-Jet** fan is made of polymer coated steel. The fans are available in two casing versions: cylindrical and octagonal.
- The casing includes inner brackets for motor fixation. These brackets act as directing vanes and distribute air flow uniformly, thus increasing aerodynamic performances of the fan. The fan has a sound insulation of mineral wool.
- The fan in an octagonal casing **Axis-Jet-VI** has a reduced height, a hinged hatch for electrical installation with captive bolts and a detachable middle part for maintenance.

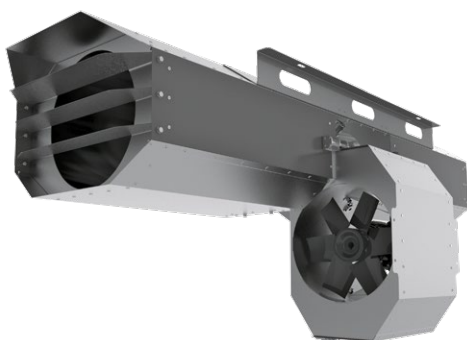

### Motor

- Three-phase asynchronous short-circuit rotor motor is installed inside the fan casing. Motor ingress protection rating is IP55. The motor design ensures operation of the fan in the smoke extract systems and/or general ventilation systems in unidirectional and reversible modes. The motors are designed for 400 V mains voltage and 50 Hz mains frequency.

### Impeller

- The dynamically balanced impeller is made of cast aluminium alloy (for fans of smoke extraction systems) or of glass-fiber reinforced polyamide (for fans of general industrial use).
- The reversible fans are equipped with 100 % reversible two-directional impeller.

### Mounting

- The **Axis-Jet** fans are designed for horizontal ceiling mounting and fixation by means of the supplied fixing brackets attached to the fan casing.

### Modifications

- Unidirectional single-speed type (U)
- Unidirectional double-speed type (U)
- Reversible single-speed (R)
- Reversible double-speed (R)

The fans with the fire resistance rating 200 °C/2 hrs can be manufactured on special request.

### Designation key

Model	Casing type	Casing insulation	Diameter [mm]	Motor	Number of poles	Air flow	Fire resistance limit/hrs
<b>AXIS-JET:</b> jet axial fan	- <b>C:</b> round <b>V:</b> octagonal	- : without sound-insulation <b>I:</b> sound-insulated casing	- <b>315; 355; 400; 450; 500; 560; 630</b>	- : standard motor <b>M, S:</b> model with a high-power motor	- <b>2</b> <b>2/4</b> (applicable for double-speed motors)	- <b>U:</b> unidirectional <b>R:</b> reversible	- : max. +55 °C <b>300/2:</b> 300 °C/2 h <b>400/2:</b> 400 °C/2 h

**Overall dimensions [mm]**

**AXIS-JET-CI**

Model	Ø D1	A	B	H	L1	L2	Weight [kg]
<b>Unidirectional</b>							
Axis-Jet-CI-315-U	414	302	355	425	1654	1763	40
Axis-Jet-CI-355-U	467	302	420	482	1954	2079	50
Axis-Jet-CI-400-U	515	351	460	525	2004	2129	65
Axis-Jet-CI-450-U	565	351	500	575	2004	2129	85
Axis-Jet-CI-500-U	603	371	580	620	2004	2145	110
Axis-Jet-CI-560-U	663	446	620	678	2093	2247	155
Axis-Jet-CI-630-U	733	550	710	748	2193	2357	245
<b>Reversible</b>							
Axis-Jet-CI-315-R	414	302	355	425	1654	1872	40
Axis-Jet-CI-355-R	467	302	420	482	1954	2202	50
Axis-Jet-CI-400-R	515	351	460	525	2004	2253	65
Axis-Jet-CI-450-R	565	351	500	575	2004	2253	85
Axis-Jet-CI-500-R	603	371	580	620	2004	2290	110
Axis-Jet-CI-560-R	663	446	620	678	2093	2400	155
Axis-Jet-CI-630-R	733	550	710	748	2193	2520	245

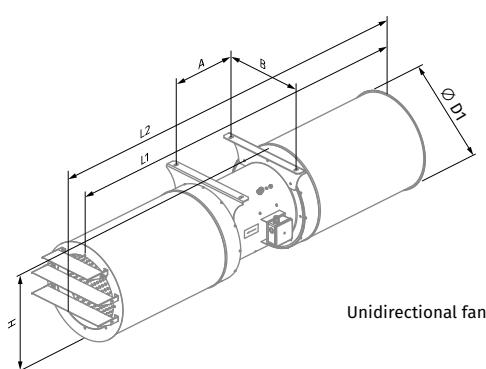

Unidirectional fan

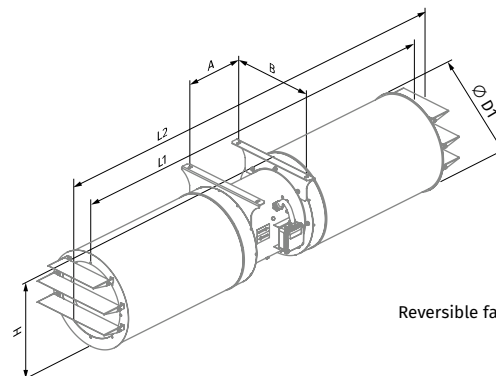

Reversible fan

**AXIS-JET-VI**

Model	Ø D1	A	B	H	L	L1	L2	Weight [kg]
<b>Unidirectional</b>								
Axis-Jet-VI-315-U	315	700	542	347	1846	507	572	58
Axis-Jet-VI-355-U	355	700	583	388	2046	546	613	75
Axis-Jet-VI-400-U	400	750	632	434	2296	590	667	95
<b>Reversible</b>								
Axis-Jet-VI-315-R	315	700	542	347	1846	507	572	58
Axis-Jet-VI-355-R	355	700	583	388	2046	546	613	75
Axis-Jet-VI-400-R	400	750	632	434	2296	590	667	95

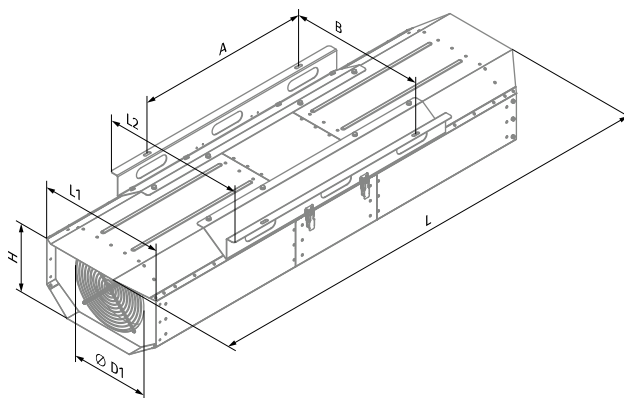

**Technical data**
**AXIS-JET-CI**

∅ [mm]	Air flow direction	Number of speeds	Model	Power [kW]	Max. air flow [m³/h]	Fan pull [N]	Air speed [m/s]	RPM	Operating temperature [°C]	Sound pressure LpA, dB in 3 m		
315	Unidirectional	1	Axis-Jet-CI-315-2-U	0.55	4520	26	17.2	2880	-25...+55 °C	63		
			Axis-Jet-CI-315-2-U-300/2				300 °C/2 h*		63			
			Axis-Jet-CI-315-2-U-400/2			14	12.4		400 °C/2 h*	63		
			Axis-Jet-CI-315M-2-U		0.75	4990	32		19	2880	-25...+55 °C	64
			Axis-Jet-CI-315M-2-U-300/2						300 °C/2 h*		64	
		Axis-Jet-CI-315M-2-U-400/2		3590	17	13.6		400 °C/2 h*	65			
		Axis-Jet-CI-315-2/4-U	0.55/0.11	2	4520/2260	26/7	17.2/8.6	2880/1440	-25...+55 °C	63/48		
		Axis-Jet-CI-315-2/4-U-300/2					300 °C/2 h*		63/48			
		Axis-Jet-CI-315-2/4-U-400/2				14/4	12.4/6.18		400 °C/2 h*	63/48		
		Axis-Jet-CI-315M-2/4-U			0.8/0.2	4990/2490	32/8		19/9.5	2880/1440	-25...+55 °C	64/49
	Axis-Jet-CI-315M-2/4-U-300/2						300 °C/2 h*		64/49			
	Axis-Jet-CI-315M-2/4-U-400/2		3590/1790	17/5	13.6/6.8		400 °C/2 h*	65/50				
	Axis-Jet-CI-315-2-R	0.55	1	4190	23	15.9	2880	-25...+55 °C	67			
	Axis-Jet-CI-315-2-R-300/2					300 °C/2 h*		67				
	Axis-Jet-CI-315-2-R-400/2				3010	12		11.4	400 °C/2 h*	68		
Axis-Jet-CI-315-2/4-R	0.55/0.11			2	4180/2100	23/6		15.9/7.9	2880/1440	-25...+55 °C	67/52	
Axis-Jet-CI-315-2/4-R-300/2								300 °C/2 h*		67/52		
Axis-Jet-CI-315-2/4-R-400/2		3010/1510	12/3	11.4/5.7		400 °C/2 h*	68/53					
355	Unidirectional	1	Axis-Jet-CI-355-2-U	0.75	5830	34	17.3	2880	-25...+55 °C	65		
			Axis-Jet-CI-355-2-U-300/2				300 °C/2 h*		65			
			Axis-Jet-CI-355-2-U-400/2			24	14.5		400 °C/2 h*	65		
			Axis-Jet-CI-355M-2-U		1.1	6740	45		20.0	2880	-25...+55 °C	64
			Axis-Jet-CI-355M-2-U-300/2						300 °C/2 h*		64	
		Axis-Jet-CI-355M-2-U-400/2		5360	29	15.9		400 °C/2 h*	67			
		Axis-Jet-CI-355-2/4-U	0.8/0.2	2	5830/3000	34/9	17.3/8.9	2880/1440	-25...+55 °C	65/50		
		Axis-Jet-CI-355-2/4-U-300/2					300 °C/2 h*		65/50			
		Axis-Jet-CI-355-2/4-U-400/2				4880/2440	24/6		14.5/7.3	400 °C/2 h*	65/50	
		Axis-Jet-CI-355M-2/4-U			1.1/0.25	2	6740/3370		45/12	20.0/10.0	2880/1440	-25...+55 °C
	Axis-Jet-CI-355M-2/4-U-300/2								300 °C/2 h*	64/49		
	Axis-Jet-CI-355M-2/4-U-400/2		5360/2680	29/8	15.9/8		400 °C/2 h*	67/52				
	Axis-Jet-CI-355-2-R	1.1	1	5810	34	17.3	2880	-25...+55 °C	68			
	Axis-Jet-CI-355-2-R-300/2					300 °C/2 h*		68				
	Axis-Jet-CI-355-2-R-400/2				5160	27		15.3	400 °C/2 h*	70		
Axis-Jet-CI-355-2/4-R	1.1/0.25			2	5810/2900	34/9		17.3/8.6	2810/1390	-25...+55 °C	68/53	
Axis-Jet-CI-355-2/4-R-300/2								300 °C/2 h*		68/53		
Axis-Jet-CI-355-2/4-R-400/2		5160/2580	27/7	15.3/7.7		400 °C/2 h*	70/55					
400	Unidirectional	1	Axis-Jet-CI-400-2-U	1.1	8500	57	20.0	2880	-25...+55 °C	69		
			Axis-Jet-CI-400-2-U-300/2				300 °C/2 h*		69			
			Axis-Jet-CI-400-2-U-400/2			39	16.4		400 °C/2 h*	70		
			Axis-Jet-CI-400M-2-U		2.2	9870	77		23.2	2880	-25...+55 °C	67
			Axis-Jet-CI-400M-2-U-300/2						300 °C/2 h*		67	
		Axis-Jet-CI-400M-2-U-400/2		8500	57	20		400 °C/2 h*	69			
		Axis-Jet-CI-400-2/4-U	1.1/0.25	2	8500/4250	57/15	20.0/10.0	2880/1440	-25...+55 °C	69/54		
		Axis-Jet-CI-400-2/4-U-300/2					300 °C/2 h*		69/54			
		Axis-Jet-CI-400-2/4-U-400/2				6970/3490	39/10		16.4/8.2	400 °C/2 h*	70/55	
		Axis-Jet-CI-400M-2/4-U			2.2/0.5	2	9870/4930		77/20	23.2/11.6	2880/1440	-25...+55 °C
	Axis-Jet-CI-400M-2/4-U-300/2								300 °C/2 h*	67/52		
	Axis-Jet-CI-400M-2/4-U-400/2		8500/4250	57/15	20/10		400 °C/2 h*	69/54				
	Axis-Jet-CI-400-2-R	1.5	1	8290	54	19.5	2880	-25...+55 °C	70			
	Axis-Jet-CI-400-2-R-300/2					300 °C/2 h*		70				
	Axis-Jet-CI-400-2-R-400/2				7140	40		16.8	400 °C/2 h*	71		
Axis-Jet-CI-400-2/4-R	1.5/0.37			2	8290/4140	54/14		19.5/9.7	2880/1440	-25...+55 °C	70/55	
Axis-Jet-CI-400-2/4-R-300/2								300 °C/2 h*		70/55		
Axis-Jet-CI-400-2/4-R-400/2		7140/3570	40/10	16.8/8.4		400 °C/2 h*	71/56					

\* Smoke extraction mode: once for two hours



**AXIS-JET-CI**

Ø [mm]	Air flow direction	Number of speeds	Model	Power [kW]	Max. air flow [m³/h]	Fan pull [N]	Air speed [m/s]	RPM	Operating temperature [°C]	Sound pressure LpA, dB in 3 m				
450	Unidirectional	1	Axis-Jet-CI-450-2-U	1.5	10400	67	19.3	2880	-25...+55 °C	67				
			Axis-Jet-CI-450-2-U-300/2						300 °C/2 h*	67				
			Axis-Jet-CI-450-2-U-400/2						400 °C/2 h*	67				
		2	1	Axis-Jet-CI-450M-2-U	2.2	12800	100	23.3	2850	-25...+55 °C	70			
				Axis-Jet-CI-450M-2-U-300/2						300 °C/2 h*	70			
				Axis-Jet-CI-450M-2-U-400/2						400 °C/2 h*	70			
			2	1	Axis-Jet-CI-450S-2-U	3	14100	124	26.2	2890	-25...+55 °C	69		
					Axis-Jet-CI-450S-2-U-300/2						300 °C/2 h*	69		
					Axis-Jet-CI-450S-2-U-400/2						400 °C/2 h*	72		
		Reversible	1	1	Axis-Jet-CI-450-2/4-U	1.5/0.37	10400/5220	67/17	19.3/9.7	2880/1440	-25...+55 °C	67/52		
					Axis-Jet-CI-450-2/4-U-300/2		300 °C/2 h*	67/52						
					Axis-Jet-CI-450-2/4-U-400/2		400 °C/2 h*	67/52						
				2	1	Axis-Jet-CI-450M-2/4-U	2.2/0.5	12800/6290	100/25	23.3/11.7	2880/1440	-25...+55 °C	70/55	
						Axis-Jet-CI-450M-2/4-U-300/2		300 °C/2 h*	70/55					
						Axis-Jet-CI-450M-2/4-U-400/2		400 °C/2 h*	70/55					
	2		1	1	Axis-Jet-CI-450S-2/4-U	3.1/0.8	14100/7070	124/31	26.2/13.1	2880/1440	-25...+55 °C	69/54		
					Axis-Jet-CI-450S-2/4-U-300/2		300 °C/2 h*	69/54						
					Axis-Jet-CI-450S-2/4-U-400/2		400 °C/2 h*	72/57						
			2	1	1	Axis-Jet-CI-450-2-R	1.5	9280	54	17.2	2880	-25...+55 °C	73	
						Axis-Jet-CI-450-2-R-300/2		300 °C/2 h*	73					
						Axis-Jet-CI-450-2-R-400/2		400 °C/2 h*	71					
				2	1	1	Axis-Jet-CI-450M-2-R	2.2	10400	67	19.2	2850	-25...+55 °C	72
							Axis-Jet-CI-450M-2-R-300/2		300 °C/2 h*	72				
							Axis-Jet-CI-450M-2-R-400/2		400 °C/2 h*	73				
	2	1	1	Axis-Jet-CI-450S-2-R	3	12800	102	23.7	2890	-25...+55 °C	74			
				Axis-Jet-CI-450S-2-R-300/2		300 °C/2 h*	74							
				Axis-Jet-CI-450S-2-R-400/2		400 °C/2 h*	74							
			2	1	1	Axis-Jet-CI-450-2/4-R	1.5/0.37	9280/4640	54/14	17.2/8.6	2880/1440	-25...+55 °C	73/58	
						Axis-Jet-CI-450-2/4-R-300/2		300 °C/2 h*	73/58					
						Axis-Jet-CI-450-2/4-R-400/2		400 °C/2 h*	71/56					
2		1	1	Axis-Jet-CI-450M-2/4-R	2.2/0.5	10400/5190	67/17	19.2/9.6	2880/1440	-25...+55 °C	72/57			
				Axis-Jet-CI-450M-2/4-R-300/2		300 °C/2 h*	72/57							
				Axis-Jet-CI-450M-2/4-R-400/2		400 °C/2 h*	73/58							
2	1	1	Axis-Jet-CI-450S-2/4-R	3.1/0.8	12800/6400	102/26	23.7/11.9	2880/1440	-25...+55 °C	74/59				
			Axis-Jet-CI-450S-2/4-R-300/2		300 °C/2 h*	74/59								
			Axis-Jet-CI-450S-2/4-R-400/2		400 °C/2 h*	74/59								
500	Unidirectional	2	Axis-Jet-CI-500-2/4-U	3.1/0.8	16200/8120	132/34	24.3/12.2	2880/1440	-25...+55 °C	72/57				
			Axis-Jet-CI-500-2/4-U-300/2		300 °C/2 h*	72/57								
			Axis-Jet-CI-500-2/4-U-400/2		400 °C/2 h*	70/55								
		2	1	Axis-Jet-CI-500M-2/4-U	4.4/1.1	18500/9240	171/43	27.7/13.8	2880/1440	-25...+55 °C	72/57			
				Axis-Jet-CI-500M-2/4-U-300/2		300 °C/2 h*	72/57							
				Axis-Jet-CI-500M-2/4-U-400/2		400 °C/2 h*	74/59							
	Reversible		2	1	Axis-Jet-CI-500-2/4-R	3.1/0.8	14500/7250	105/27	21.7/10.8	2880/1440	-25...+55 °C	77/62		
					Axis-Jet-CI-500-2/4-R-300/2		300 °C/2 h*	77/62						
					Axis-Jet-CI-500-2/4-R-400/2		400 °C/2 h*	75/60						
		2	1	1	Axis-Jet-CI-500M-2/4-R	4.4/1.1	16600/8310	138/35	24.8/12.4	2880/1440	-25...+55 °C	76/61		
					Axis-Jet-CI-500M-2/4-R-300/2		300 °C/2 h*	76/61						
					Axis-Jet-CI-500M-2/4-R-400/2		400 °C/2 h*	77/62						
560	Unidirectional	2	Axis-Jet-CI-560-2/4-U	4.4/1.1	20200/10100	167/42	24.7/12.4	2880/1440	-25...+55 °C	74/59				
			Axis-Jet-CI-560-2/4-U-300/2		300 °C/2 h*	74/59								
			Axis-Jet-CI-560-2/4-U-400/2		400 °C/2 h*	74/59								
		2	1	Axis-Jet-CI-560M-2/4-U	8/2	25100/12500	257/64	30.7/15.3	2880/1440	-25...+55 °C	76/61			
				Axis-Jet-CI-560M-2/4-U-300/2		300 °C/2 h*	76/61							
				Axis-Jet-CI-560M-2/4-U-400/2		400 °C/2 h*	77/62							
	Reversible		2	1	Axis-Jet-CI-560-2/4-R	4.4/1.1	16800/8410	115/29	20.5/10.3	2880/1440	-25...+55 °C	77/62		
					Axis-Jet-CI-560-2/4-R-300/2		300 °C/2 h*	77/62						
					Axis-Jet-CI-560-2/4-R-400/2		400 °C/2 h*	77/62						
		2	1	1	Axis-Jet-CI-560M-2/4-R	6/1.5	21100/10500	182/46	25.8/12.9	2880/1440	-25...+55 °C	79/64		
					Axis-Jet-CI-560M-2/4-R-300/2		300 °C/2 h*	79/64						
					Axis-Jet-CI-560M-2/4-R-400/2		400 °C/2 h*	77/62						

\* Smoke extraction mode: once for two hours

**AXIS-JET-CI**

∅ [mm]	Air flow direction	Number of speeds	Model	Power [kW]	Max. air flow [m³/h]	Fan pull [N]	Air speed [m/s]	RPM	Operating temperature [°C]	Sound pressure LpA, dB in 3 m
630	Unidirectional	2	Axis-Jet-CI-630-2/4-U	12/3	31500/15700	320/80	30.4/15.2	2880/1440	-25...+55 °C	79/64
			Axis-Jet-CI-630-2/4-U-300/2						300 °C/2 h*	79/64
			Axis-Jet-CI-630-2/4-U-400/2						400 °C/2 h*	77/62
			Axis-Jet-CI-630M-2/4-U	16/4	35200/17650	399/101	34/17		-25...+55 °C	81/66
			Axis-Jet-CI-630M-2/4-U-300/2						300 °C/2 h*	81/66
			Axis-Jet-CI-630M-2/4-U-400/2						400 °C/2 h*	78/63
	Reversible	2	Axis-Jet-CI-630-2/4-R	12/3	26700/13400	230/58	25.8/12.9	2880/1440	-25...+55 °C	85/70
			Axis-Jet-CI-630-2/4-R-300/2						300 °C/2 h*	85/70
			Axis-Jet-CI-630-2/4-R-400/2						400 °C/2 h*	82/67
			Axis-Jet-CI-630M-2/4-R	16/4	29100/14600	274/69	28.2/14.1		-25...+55 °C	86/71
			Axis-Jet-CI-630M-2/4-R-300/2						300 °C/2 h*	86/71
			Axis-Jet-CI-630M-2/4-R-400/2						400 °C/2 h*	82/67

\* Smoke extraction mode: once for two hours

**AXIS-JET-VI**

Ø [mm]	Air flow direction	Number of speeds	Model	Power [kW]	Max. air flow [m³/h]	Fan pull [N]	Air speed [m/s]	RPM	Operating temperature °C	Sound pressure LpA, dB in 3 m
315	Unidirectional	1	Axis-Jet-VI-315-2-U	0.55	4520	26	17.2	2880	-25...+55 °C	63
			Axis-Jet-VI-315-2-U-300/2						300 °C/2 h*	63
			Axis-Jet-VI-315-2-U-400/2						400 °C/2 h*	63
		2	0.75	Axis-Jet-VI-315M-2-U	4990	32	19	2880	-25...+55 °C	64
				Axis-Jet-VI-315M-2-U-300/2					300 °C/2 h*	64
				Axis-Jet-VI-315M-2-U-400/2					400 °C/2 h*	65
			0.55/0.11	Axis-Jet-VI-315-2/4-U	4520/2260	26/7	17.2/8.6	2880/1440	-25...+55 °C	63/48
				Axis-Jet-VI-315-2/4-U-300/2					300 °C/2 h*	63/48
				Axis-Jet-VI-315-2/4-U-400/2					400 °C/2 h*	63/48
				Axis-Jet-VI-315M-2/4-U					4990/2490	32/8
	Axis-Jet-VI-315M-2/4-U-300/2	300 °C/2 h*	64/49							
	Reversible	1	Axis-Jet-VI-315-2-R	4190	23	15.9	2880	-25...+55 °C	67	
			Axis-Jet-VI-315-2-R-300/2					300 °C/2 h*	67	
			Axis-Jet-VI-315-2-R-400/2					400 °C/2 h*	68	
		2	Axis-Jet-VI-315-2/4-R	4180/2100	23/6	15.9/7.9	2880/1440	-25...+55 °C	67/52	
Axis-Jet-VI-315-2/4-R-300/2			300 °C/2 h*					67/52		
Axis-Jet-VI-315-2/4-R-400/2	3010/1510	12/3	11.4/5.7		400 °C/2 h*	68/53				
355	Unidirectional	1	Axis-Jet-VI-355-2-U	0.75	5830	34	17.3	2880	-25...+55 °C	65
			Axis-Jet-VI-355-2-U-300/2						300 °C/2 h*	65
			Axis-Jet-VI-355-2-U-400/2						400 °C/2 h*	65
		2	1.1	Axis-Jet-VI-355M-2-U	6740	45	20.0	2880	-25...+55 °C	64
				Axis-Jet-VI-355M-2-U-300/2					300 °C/2 h*	64
				Axis-Jet-VI-355M-2-U-400/2					400 °C/2 h*	67
			0.8/0.2	Axis-Jet-VI-355-2/4-U	5830/3000	34/9	17.3/8.9	2880/1440	-25...+55 °C	65/50
				Axis-Jet-VI-355-2/4-U-300/2					300 °C/2 h*	65/50
				Axis-Jet-VI-355-2/4-U-400/2					400 °C/2 h*	65/50
				Axis-Jet-VI-355M-2/4-U					6740/3370	45/12
	Axis-Jet-VI-355M-2/4-U-300/2	300 °C/2 h*	64/49							
	Axis-Jet-VI-355M-2/4-U-400/2	5360/2680	29/8	15.9/8		400 °C/2 h*	67/52			
	Reversible	1	Axis-Jet-VI-355-2-R	5810	34	17.3	2880	-25...+55 °C	68	
			Axis-Jet-VI-355-2-R-300/2					300 °C/2 h*	68	
			Axis-Jet-VI-355-2-R-400/2					400 °C/2 h*	70	
2		Axis-Jet-VI-355-2/4-R	5810/2900	34/9	17.3/8.6	2810/1390	-25...+55 °C	68/53		
		Axis-Jet-VI-355-2/4-R-300/2					300 °C/2 h*	68/53		
Axis-Jet-VI-355-2/4-R-400/2	5160/2580	27/7	15.3/7.7		400 °C/2 h*	70/55				
400	Unidirectional	1	Axis-Jet-VI-400-2-U	1.1	8500	57	20.0	2880	-25...+55 °C	69
			Axis-Jet-VI-400-2-U-300/2						300 °C/2 h*	69
			Axis-Jet-VI-400-2-U-400/2						400 °C/2 h*	70
		2	2.2	Axis-Jet-VI-400M-2-U	9870	77	23.2	2880	-25...+55 °C	67
				Axis-Jet-VI-400M-2-U-300/2					300 °C/2 h*	67
				Axis-Jet-VI-400M-2-U-400/2					400 °C/2 h*	69
			1.1/0.25	Axis-Jet-VI-400-2/4-U	8500/4250	57/15	20.0/10.0	2880/1440	-25...+55 °C	69/54
				Axis-Jet-VI-400-2/4-U-300/2					300 °C/2 h*	69/54
				Axis-Jet-VI-400-2/4-U-400/2					400 °C/2 h*	70/55
				Axis-Jet-VI-400M-2/4-U					9870/4930	77/20
	Axis-Jet-VI-400M-2/4-U-300/2	300 °C/2 h*	67/52							
	Axis-Jet-VI-400M-2/4-U-400/2	8500/4250	57/15	20/10		400 °C/2 h*	69/54			
	Reversible	1	Axis-Jet-VI-400-2-R	8290	54	19.5	2880	-25...+55 °C	70	
			Axis-Jet-VI-400-2-R-300/2					300 °C/2 h*	70	
			Axis-Jet-VI-400-2-R-400/2					7140	40	16.8
2		Axis-Jet-VI-400-2/4-R	8290/4140	54/14	19.5/9.7	2880/1440	-25...+55 °C	70/55		
		Axis-Jet-VI-400-2/4-R-300/2					300 °C/2 h*	70/55		
Axis-Jet-VI-400-2/4-R-400/2	7140/3570	40/10	16.8/8.4		400 °C/2 h*	71/56				

\* Smoke extraction mode: once for two hours

# CENTRO-JET

## Induction centrifugal fans

### Use

- Induction centrifugal fans **Centro-Jet** are designed for general purpose ventilation of underground and semiopened parkings, smoke extraction in case of fire as a part of smoke extract system. The fans generate a high-speed and high-pressure directed air jet.



### Design

- Centro-Jet casing is made of polymer coated steel.
- Due to low height of the casing the fan is recommended for use in low-ceilinged room.
- The protecting grille on the intake side prevents ingress of foreign objects into the fan.
- Deflector plates on the exhaust side of the fan ensure correct air flow distribution.

### Modifications

- Single-speed
- Double-speed

### Motor

- Single- or double-speed 4-, 6- or 8-pole asynchronous motors are used. The motor ingress protection rating is IP55. The motors are rated for 400 V power mains voltage and 50 Hz frequency.

### Impeller

- The impeller with backward curved steel blades.

### Mounting

- The Centro-Jet fans are designed for ceiling mounting and fixation by means of the supplied fixing brackets. Power is supplied through the internal terminal box. The fan wiring and mounting must be made according to the instructions and the wiring diagram shown in the terminal box.

### Overall dimensions [mm]

Model	A	B	C	H	K	Weight [kg]
<b>Centro-Jet-50N</b>	290	1355	935	90	350	96
<b>Centro-Jet-85N</b>	330	1605	1105	110	390	136
<b>Centro-Jet-100N</b>	330	1605	1105	110	390	138

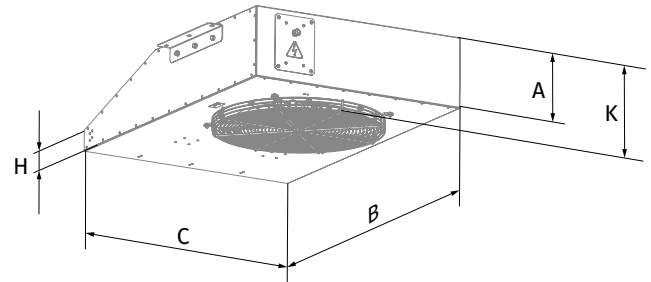

The fans with the fire resistance rating 200 °C/2 hrs can be manufactured on special request.

### Designation key

Model	Fan pull [N]	Number of poles	Fire resistance limit/hrs
<b>CENTRO-JET:</b> Induction centrifugal fan	- <b>50N</b> <b>85N</b> <b>100N</b>	- <b>4</b> <b>4/6</b> (applicable for double-speed models) <b>4/8</b> (applicable for double-speed models)	- <b>—</b> : max. +55 °C <b>300/2</b> : 300 °C/2 h <b>400/2</b> : 400 °C/2 h

## Technical data

Model	Number of speeds	Max. air flow [m <sup>3</sup> /h]	Power [kW]	Fan pull [N]	Air speed [m/s]	RPM	Operating temperature [°C]	Sound pressure LpA, dB in 3 m
Centro-Jet-50N-4							-25...+55 °C	
Centro-Jet-50N-4-300/2	1	6200	1.5	50	20.5	1500	300 °C/2 h*	72
Centro-Jet-50N-4-400/2							400 °C/2 h*	
Centro-Jet-50N-4/6							-25...+55 °C	
Centro-Jet-50N-4/6-300/2		6200/4100	1.5/0.37	50/20	20.5/13.5	1500/1000	300 °C/2 h*	72/59
Centro-Jet-50N-4/6-400/2							400 °C/2 h*	
Centro-Jet-50N-4/8	2						-25...+55 °C	
Centro-Jet-50N-4/8-300/2		6200/3100	1.6/0.4	50/13	20.5/10.2	1500/750	300 °C/2 h*	72/57
Centro-Jet-50N-4/8-400/2							400 °C/2 h*	
Centro-Jet-85N-4							-25...+55 °C	
Centro-Jet-85N-4-300/2	1	9750	2.2	85	22.3	1500	300 °C/2 h*	76
Centro-Jet-85N-4-400/2							400 °C/2 h*	
Centro-Jet-85N-4/6							-25...+55 °C	
Centro-Jet-85N-4/6-300/2		9750/5950	2.2/0.7	85/28	22.3/13.6	1500/1000	300 °C/2 h*	76/63
Centro-Jet-85N-4/6-400/2							400 °C/2 h*	
Centro-Jet-85N-4/8	2						-25...+55 °C	
Centro-Jet-85N-4/8-300/2		9750/4150	2.2/0.55	85/20	22.3/9.5	1500/750	300 °C/2 h*	76/60
Centro-Jet-85N-4/8-400/2							400 °C/2 h*	
Centro-Jet-100N-4							-25...+55 °C	
Centro-Jet-100N-4-300/2	1	10200	3	100	23.3	1500	300 °C/2 h*	78
Centro-Jet-100N-4-400/2							400 °C/2 h*	
Centro-Jet-100N-4/8							-25...+55 °C	
Centro-Jet-100N-4/8-300/2	2	10200/5150	2.8/0.7	100/26	23.3/11.8	1500/750	300 °C/2 h*	78/63
Centro-Jet-100N-4/8-400/2							400 °C/2 h*	

\* Smoke extraction mode: once for two hours

# VENTILATION SYSTEM FOR UNDERROOF PARKING

VENTILATION SYSTEM FOR UNDERROOF PARKING

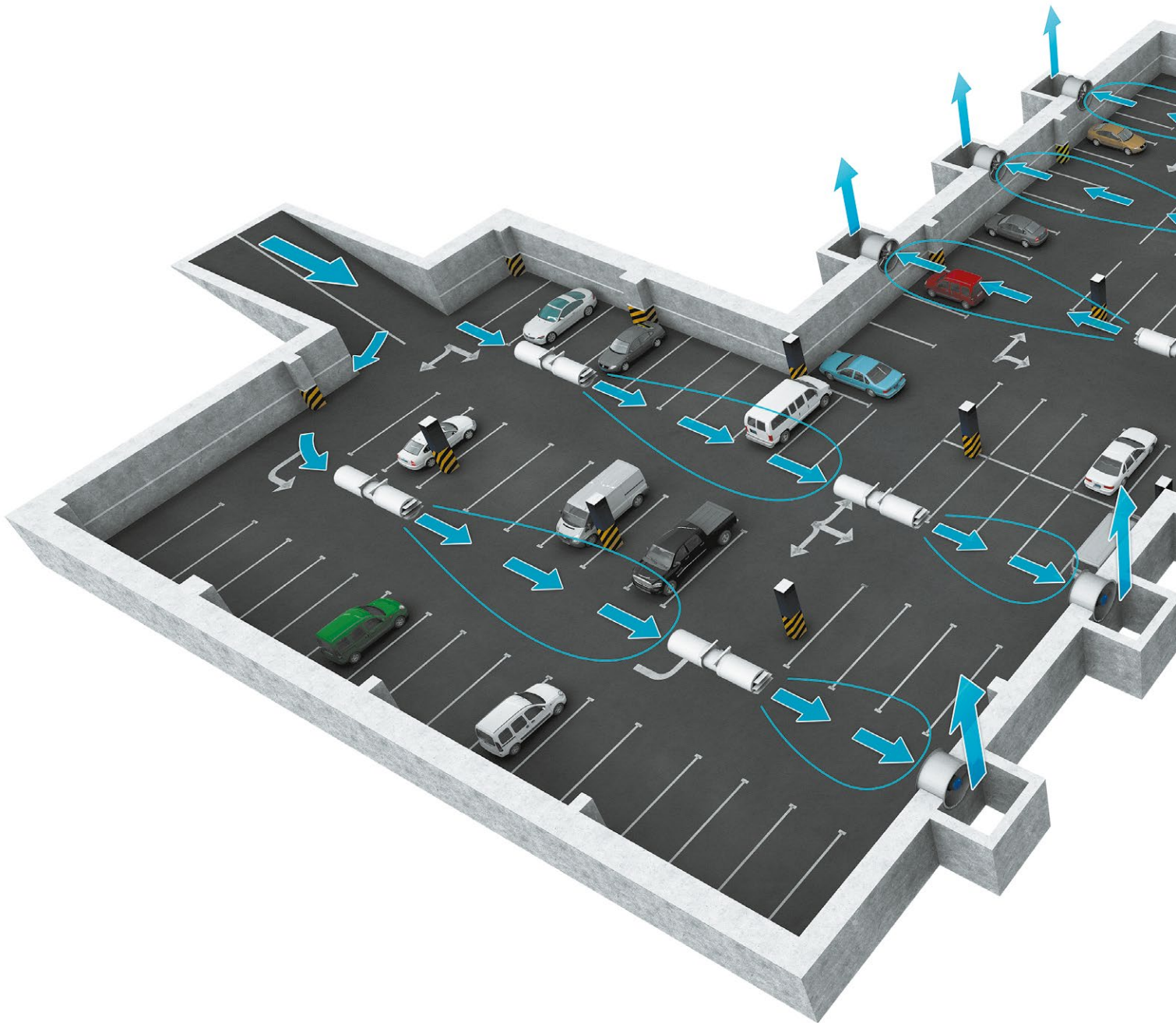

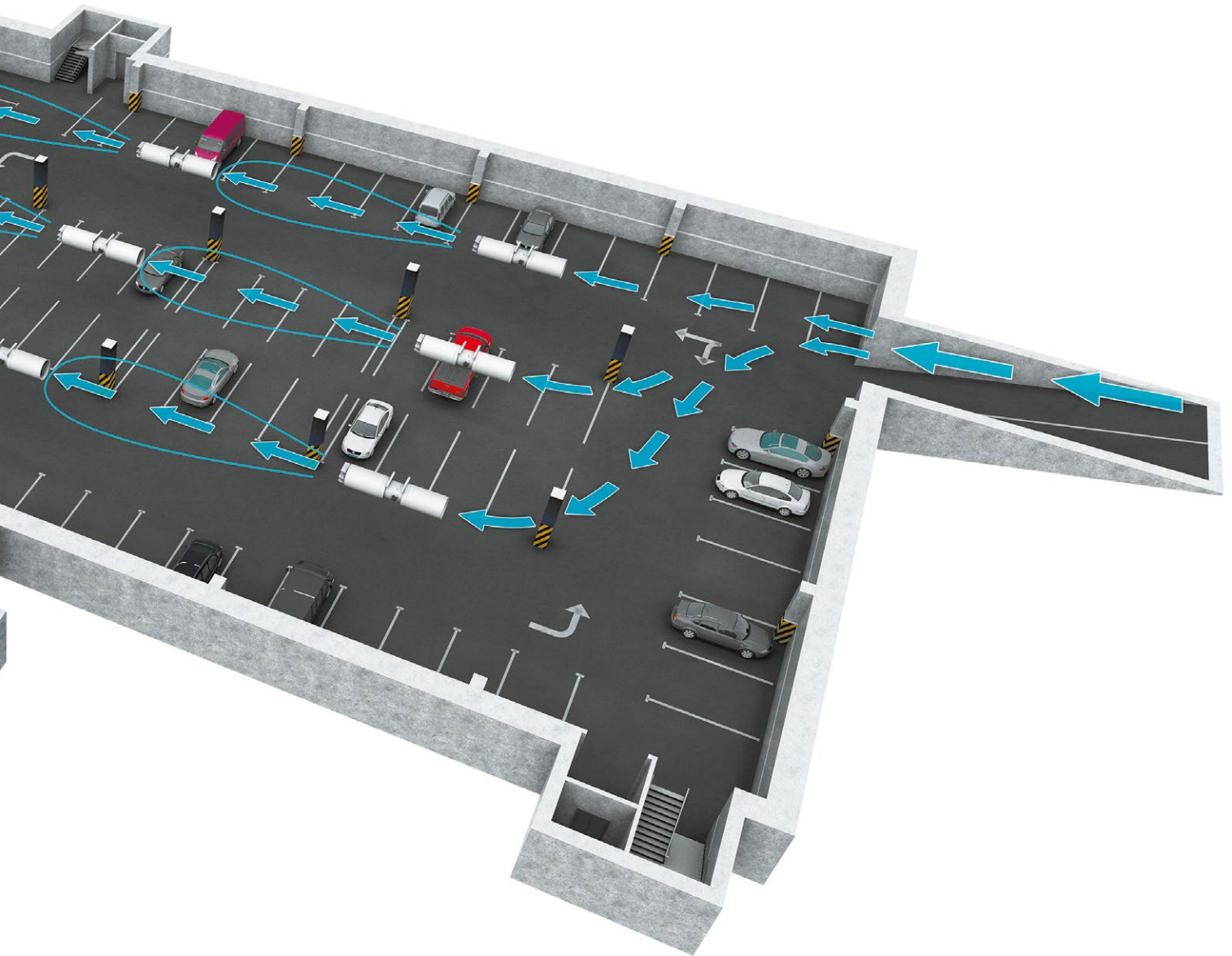

VENTILATION SYSTEM FOR UNDERROOF PARKING

## SMOKE EXTRACTION SYSTEM FOR UNDERROOF PARKING

SMOKE EXTRACTION SYSTEM FOR UNDERROOF PARKING

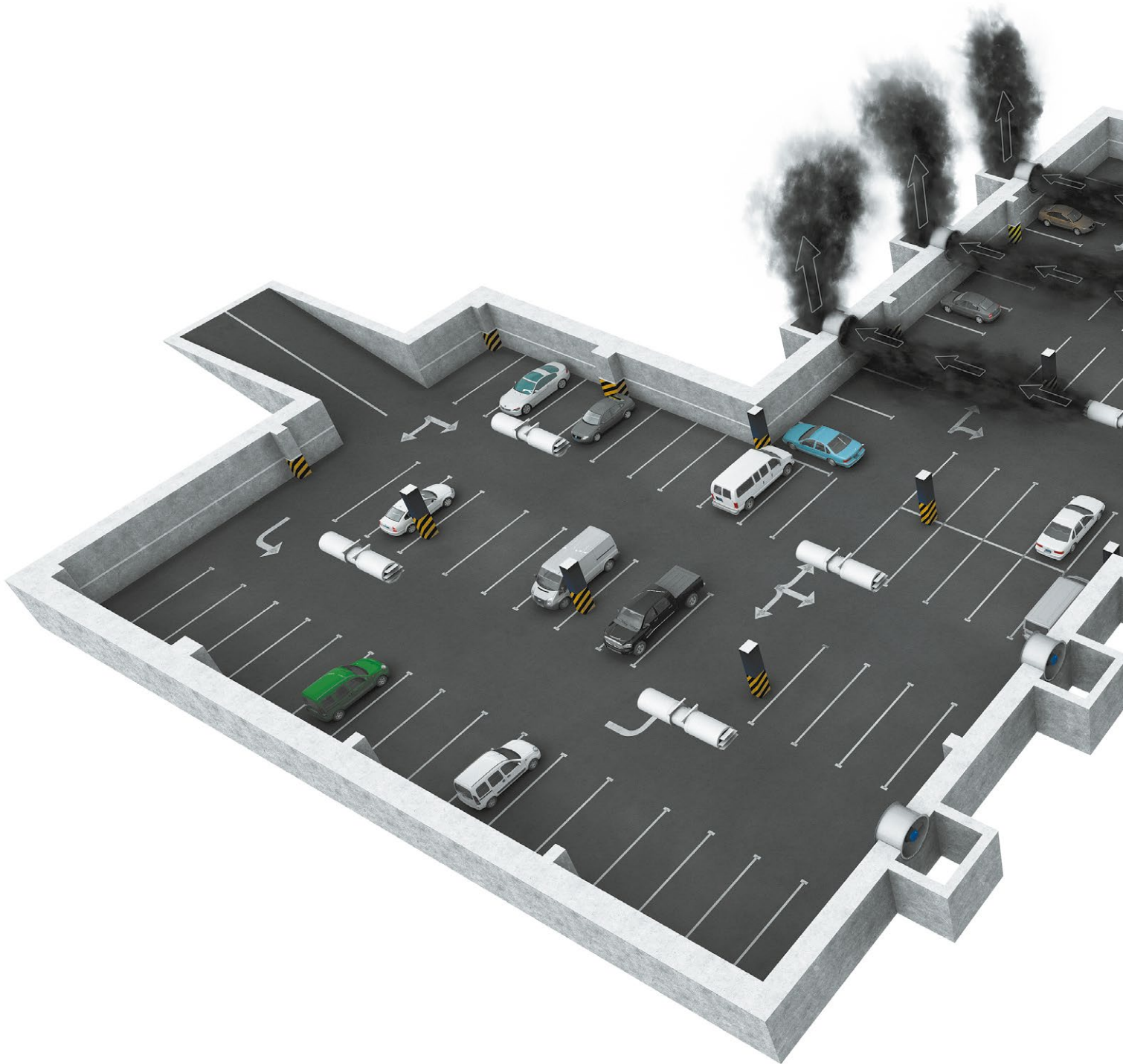



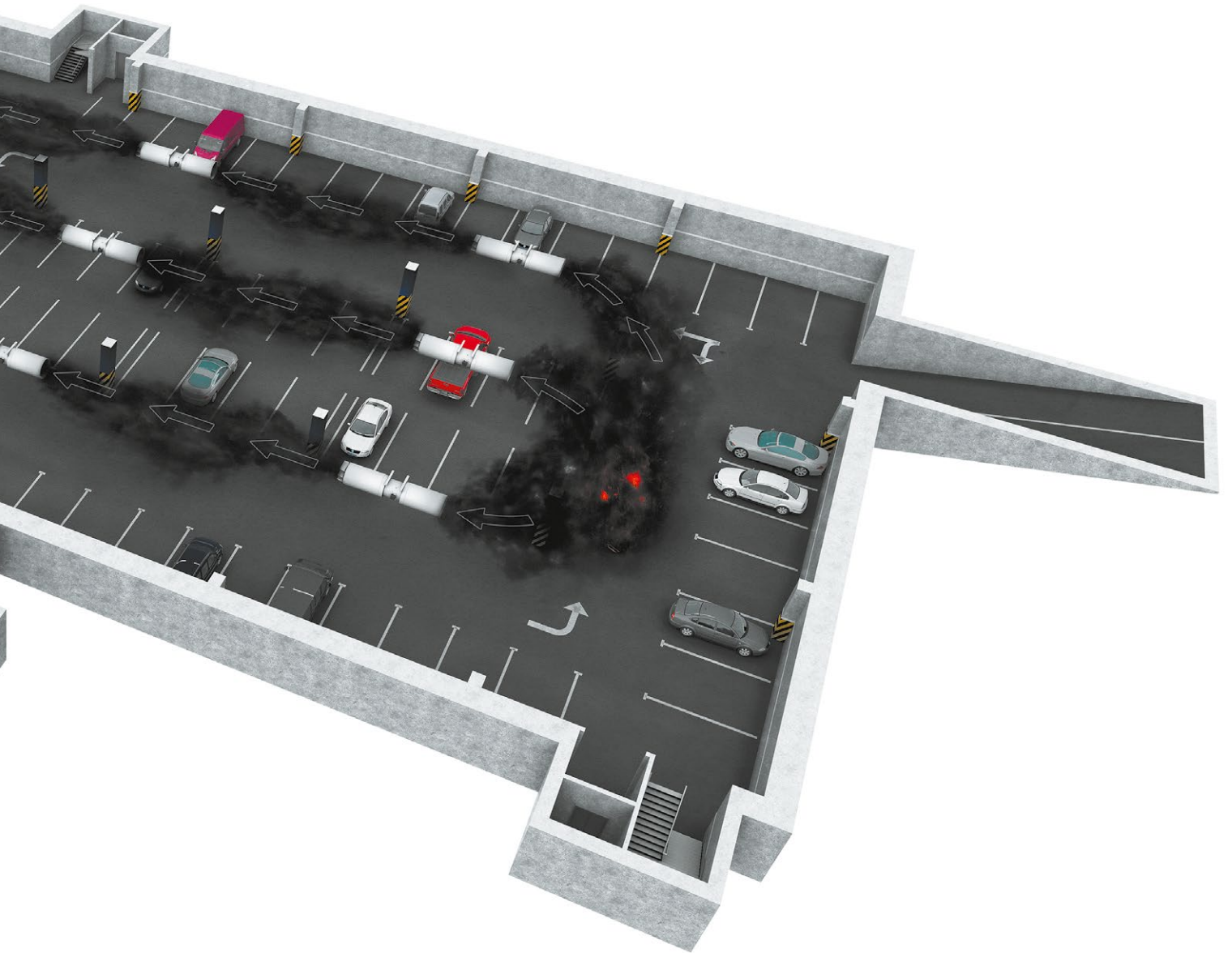

SMOKE EXTRACTION SYSTEM FOR UNDERROOF  
PARKING

# OPERATION OF FANS WITH FREQUENCY CONVERTERS

Ventilation systems produce a heavy load on the electrical systems of a building. Therefore, reducing the power consumption is among the top priorities for construction project designers.

## DIRECT ON-LINE STARTING (DOL)

As a rule, smoke extraction systems utilize large high-performance fans. During starting the high inertia of the shaft causes a substantial increase in the start-up time – i.e. the time from the application of power to reaching the rated speed. As a result the motor is subjected to high starting current for a prolonged period of time.

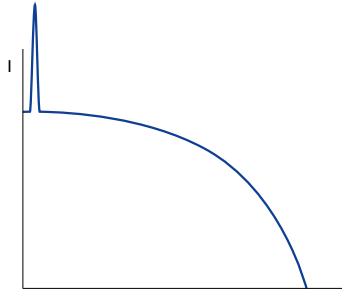

Current diagram with direct on-line starting

Standard switchgear (automatic circuit breakers, contactors and motor starters) is not designed to withstand prolonged overloads causing the fan to shut down automatically during starting.

Using switchgear with a higher maximum current rating renders the electric motor protection system less sensitive.

As a result the switchgear will not be able to detect motor overload in time due to a higher current sensing threshold.

Such challenges can only be addressed by utilizing a soft starter or a frequency converter to start the fan without causing a prolonged overload.

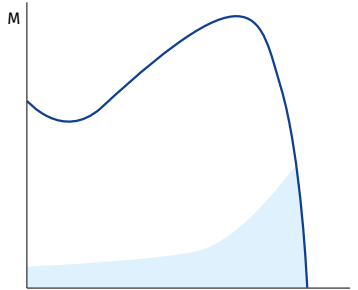

Torque diagram with direct on-line starting

## FREQUENCY CONVERTER

A frequency converter (FC) consists of two main component blocks. One converts alternating current (50 or 60 Hz) into direct current.

The other converts direct current into alternating current of variable frequency ranging from 0 to 250 Hz.

By controlling the frequency output the FC offers a broad range of motor speed regulation.

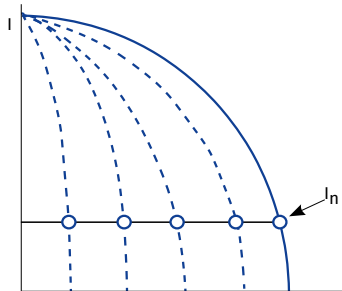

Current diagram with FC starting

During the starting the FC raises the frequency from 0 Hz to the electrical mains frequency (50 or 60 Hz).

As the frequency is increased gradually, the motor can be assumed to operate at its nominal speed for a given frequency value.

Furthermore, on the assumption that the motor runs at its nominal speed the nominal torque should be immediately available whereas the current will be approximately equal to the nominal value.

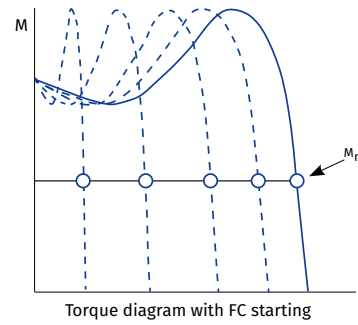

Torque diagram with FC starting

## SOFT STARTER

Unlike an FC, a soft starter does not change the frequency of speed.

Instead it gradually increases the voltage supplied to the motor – from the initial level to the nominal level.

The very low voltage initially supplied to the motor during starting helps avoid sudden jolts.

Both voltage and torque increase gradually.

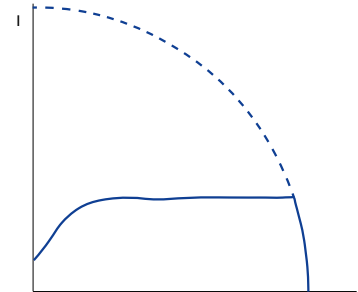

Current diagram with soft starter

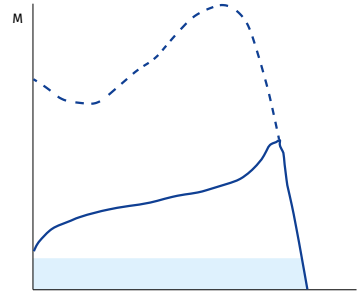

Torque diagram with soft starter

## APPLICATIONS IN VENTILATION SYSTEMS

Using an FC or a soft starter allows to reduce the starting current thereby avoiding a loss of voltage in the electrical mains.

In addition to that the starting torque and mechanical strain on equipment are also reduced which translates into extended maintenance and repair intervals.

General exhaust ventilation (GV) systems and emergency smoke extraction (SE) systems of car parks, warehouses, utility and industrial spaces can be integrated into a single system at the design level.

As the air flow rate a GV system is considerably lower than that in an SE system a high-capacity fan rated for smoke extraction duty runs in partial load mode.

Frequency converters can be programmed for several fixed-speed settings to enable operation in GV and SE modes.

The fan operating modes can be switched upon receiving an external signal from the control system.

Such integration of ventilation systems allows overall cost savings.

## FC-51 AND FC-101: WHEN TO USE?

This catalogue features two series of frequency converters: FC-51 and FC-101.

The FC-51 series is only suitable for general ventilation systems.

If intended for a smoke extraction system, the fans should be fitted with the FC-101 series units as they feature an integrated fire mode.

When activated the integrated protection equipment of the frequency converter is overridden enabling the unit to continue operation despite the possibility of sustaining irreparable damage due to overheating or overloading.

In case of a fire, the FC-101 series frequency converters are capable of maintaining a higher air pressure level at landings compared to other areas of the building in order to keep the landings smoke-free.

# MICRO DRIVE FC-51

## Frequency converters



### Use

- o This general-purpose variable frequency drive is designed for regulating the rotation speed of an AC electric motor with a maximum power output of 22 kW.
- o This unit is only suitable for general ventilation systems.

### Features

- o The drive construction prevents forced air flow passage through its internal electronic components.
- o The internal circuit boards are well-protected.

### Filter

- o The unit features an integrated HF filter which blocks RF interference from the motor and enables the use of a shielded cable up to 15 m long or unshielded cable up to 50 m long as per the applicable EU regulations.

### Inputs and outputs

- o 5 programmable digital inputs
- o PNP/NPN logic
- o 20-5000 Hz pulse input
- o One 0-10 V or 0-20 mA analogue input
- o One 0-20 mA analogue input
- o Thermistor input (analogue or digital)
- o 1 analogue output
- o 1 relay, 240 V, 2 A
- o RS 485
- o MODBUS RTU

### Control panels



Designation	Code
VLT control panel LCP 11 (without potentiometer)	132B0100
VLT Control Panel LCP 12 (with potentiometer)	132B0101



Designation	Code
Remote panel mounting kit	132B0102

### Installation

- o Back-to-back installation for space savings. Thanks to a compact design the drives can be mounted immediately next to one another without any performance penalties.

### Frequency converter type and order code

Three-phase, 380-480 V			
Power [kW]	Rated current [A]	Order code	Block type
0.37	1.2	132F0017	M1
0.75	2.2	132F0018	M1
1.5	3.7	132F0020	M2
2.2	5.3	132F0022	M2
3.0	7.2	132F0024	M3
4.0	9.0	132F0026	M3
5.5	12.0	132F0028	M3
7.5	15.5	132F0030	M3
11.0	23.0	132F0058	M4
15.0	31.0	132F0059	M4
18.0	37.0	132F0060	M5
22.0	43.0	132F0061	M5

### Outside dimensions (including mounting ledge)

mm	M1	M2	M3	M4	M5
Height	150	176	239	292	335
Width	70	75	90	125	165
Depth	148	168	194	241	248

+ 6 mm with potentiometer

# BASIC DRIVE FC-101

## Frequency converters



### Use

- This general-purpose variable frequency drive is designed for regulating the rotation speed of an AC electric motor with a maximum power output of 90 kW.
- This drive is suitable for both general ventilation and smoke extraction ventilation systems.

### Certified fire mode

- The fire mode prevents the drive from a self-protecting shut-down. While in this mode the drive continues to perform speed regulation duty for mission-critical fans irrespective of control signals, warnings and alarms which may otherwise force it shut down.

### Filter

- A built-in throttle on the DC link ensures a low harmonic load on the power mains as per the EN 61000-3-12 standard requirements.

### Inputs and outputs

- Four PNP or NPN programmable digital inputs, 0-24 V DC
- 2 analogue inputs (0-10 V or 0/4-20 mA)
- 2 analogue outputs (0/4-20 mA)
- 2 relay outputs
- MODBUS RTU (RS 485)
- BACnet MSTP
- FC Protocol
- N2 Metasys
- FLN Apogee

### Installation

- Thanks to an ultra-compact design the drive can be easily fitted into a larger unit or panel of an air ventilation system. The casings are rated IP20/Type 1/IP21 (optional) and IP54.

### Frequency converter type and SKU code

Power [kW]	Current [A]	VLT® FC 101 HVAC Basic Drive 0.37-90 kW (3 x 380 – 480 V~, without a braking transistor)			
0.37	1.2	-	131L9861	-	-
0.75	2.2	-	131L9862	131N0177	131N0178
1.5	3.7	-	131L9863	131N0179	131N0180
2.2	5.3	-	131L9864	131N0181	131N0182
3	7.2	-	131L9865	131N0183	131N0184
4	9.1	-	131L9866	131N0185	131N0186
5.5	12	-	131L9867	131N0187	131N0188
7.5	15.5	-	131L9868	131N0189	131N0190
11	23	-	131L9869	131N0191	131N0192
15	31	-	131L9870	131N0193	131N0194
18	37	-	131L9871	131N0195	131N0196
22	42.5	-	131L9872	131N0197	131N0198
30	61	131L9873	131L9875	131N0201	131N0202
37	73	131L9881	131L9883	131N0205	131N0206
45	90	131L9889	131L9891	131N0209	131N0210
55	106	131L9897	131L9899	131N0213	131N0214
75	147	131L9905	131L9907	131N0217	131N0218
90	177	131L9913	131L9915	131N0221	131N0222
Casing	(E20) IP20/Chassis	(E20) IP20/Chassis	IP54	IP54	
EMC filter	(H2) RFI class A2 (for industrial areas)	(H3/H4) RFI class A1/B (for residential areas)	(H2) RFI class A2 (for industrial areas)	(H3) RFI class A1/B (for residential areas)	
Control panel	(X) without panel	(X) without panel	Integral	Integral	

VLT® HVAC Basic frequency converters rated up to 22 kW are fitted with circuit boards with a special class 3C3 protective coating. For frequency converters rated higher than 22 kW this protective coating is optional while, the 3C2 coating is standard.

### VLT® FC 101 HVAC Basic Drive frequency converter options

Order code	Description
132B0200	Operator's digital panel
132B0201	Kit for remote mounting of the operator panel to an IP55 cabinet, including 3 m cable
132B0202	Decoupling plate for H1 and H2 standard sizes
132B0204	Decoupling plate for H3 standard size
132B0205	Decoupling plate for H4 and H5 standard sizes
132B0207	Decoupling plate for H6 standard size
132B0242	Decoupling plate for H6 standard size (extra large)

Order code	Description
132B0208	Decoupling plate for H7 standard size
132B0243	Decoupling plate for H7 standard size (extra large)
132B0209	Decoupling plate for H8 standard size
132B0244	External EMC filter class A1/B1 for power output from 0.37 to 2.2 kW
132B0245	External EMC filter class A1/B1 for power output from 3 to 7.5 kW
132B0246	External EMC filter class A1/B1 for power output from 11 to 15 kW
132B0247	External EMC filter class A1/B1 for power output from 18.5 to 22 kW



Blauberg Ventilatoren GmbH  
Aidenbachstr. 52  
D-81379 Munich

[info@blaubergventilatoren.de](mailto:info@blaubergventilatoren.de)  
[www.blaubergventilatoren.de](http://www.blaubergventilatoren.de)

Technical changes reserved.  
Illustrations and texts are non-binding.